

2001 ALL DYNA DOM. AND INT. MODELS (EXCEPT FXDWG), CHARGING CIRCUIT

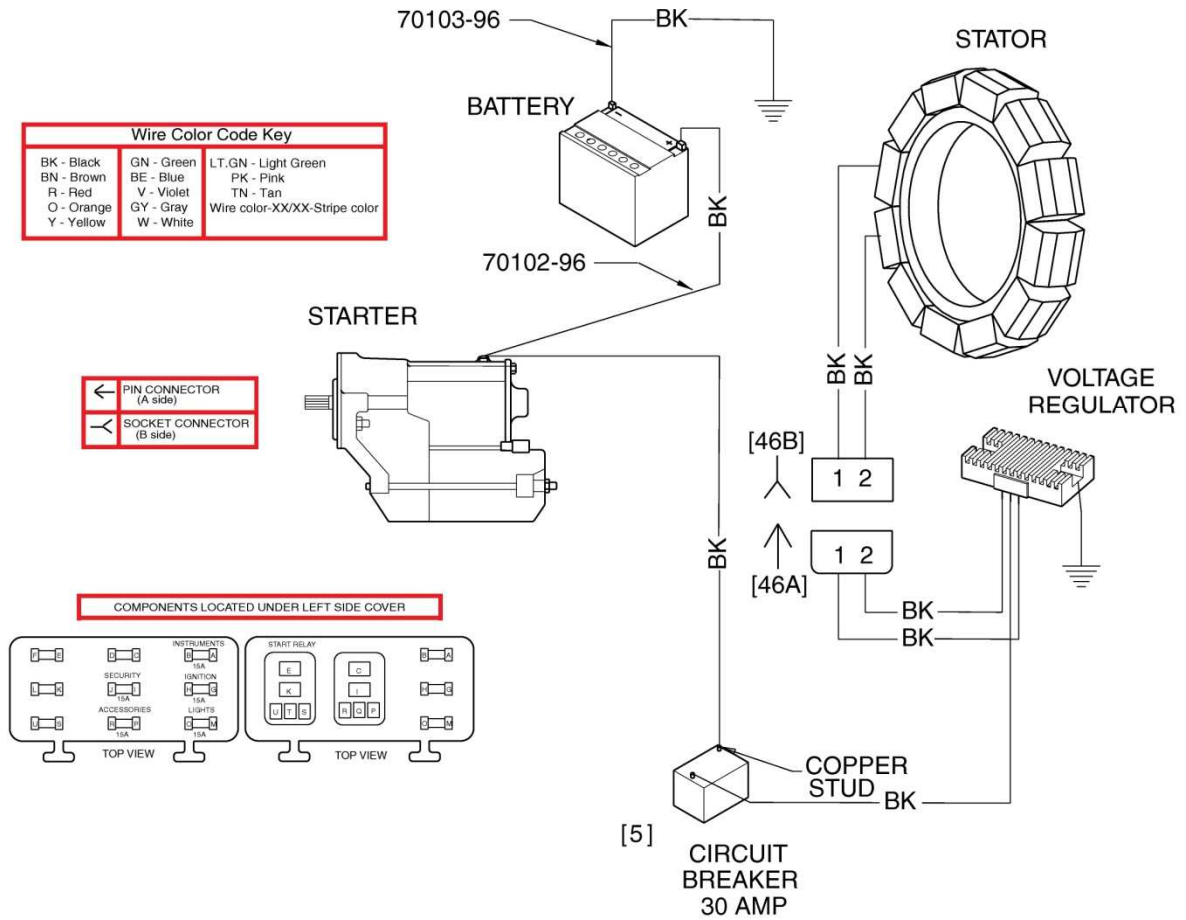

WWW.OFFICIALHARLEYPARTS.COM

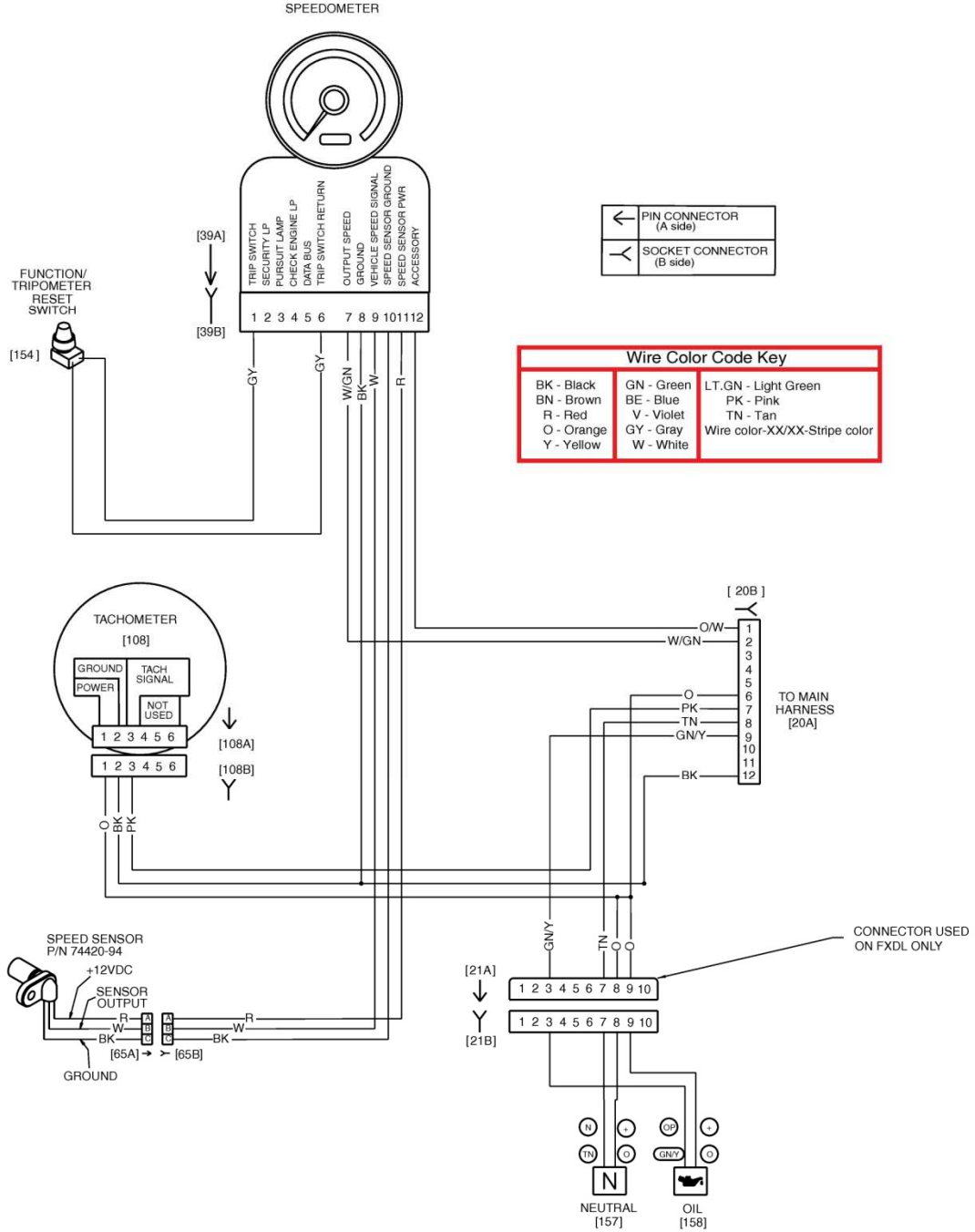

2001 ALL DYNA DOM. AND INT. MODELS (EXCEPT FXDW6), LIGHTS, INSTRUMENTS AND INDICATORS

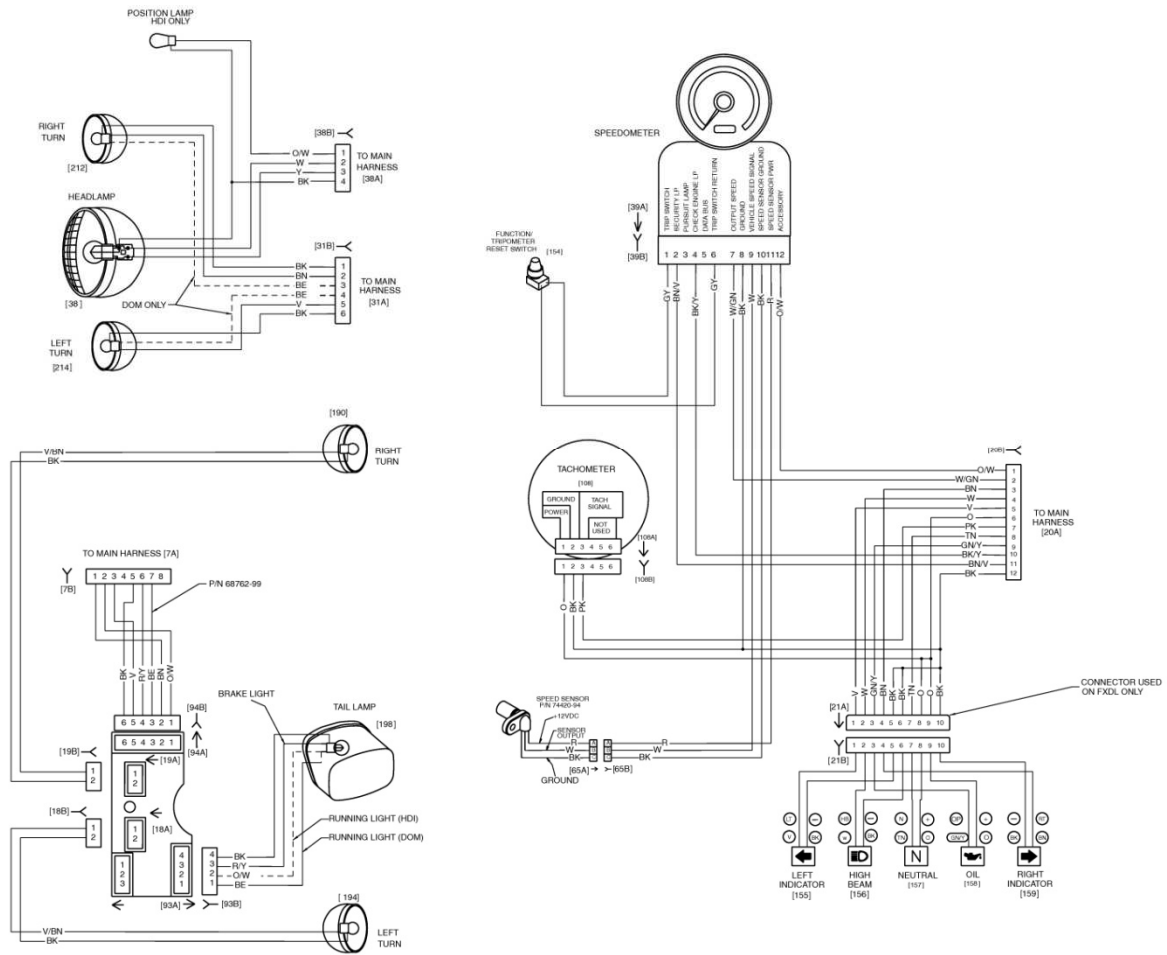

WWW.OFFICIALHARLEYPARTS.COM

2001 ALL DYNA DOM. AND INT. MODELS (EXCEPT FXDWG), LIGHTS, PAGE 1 OF 2

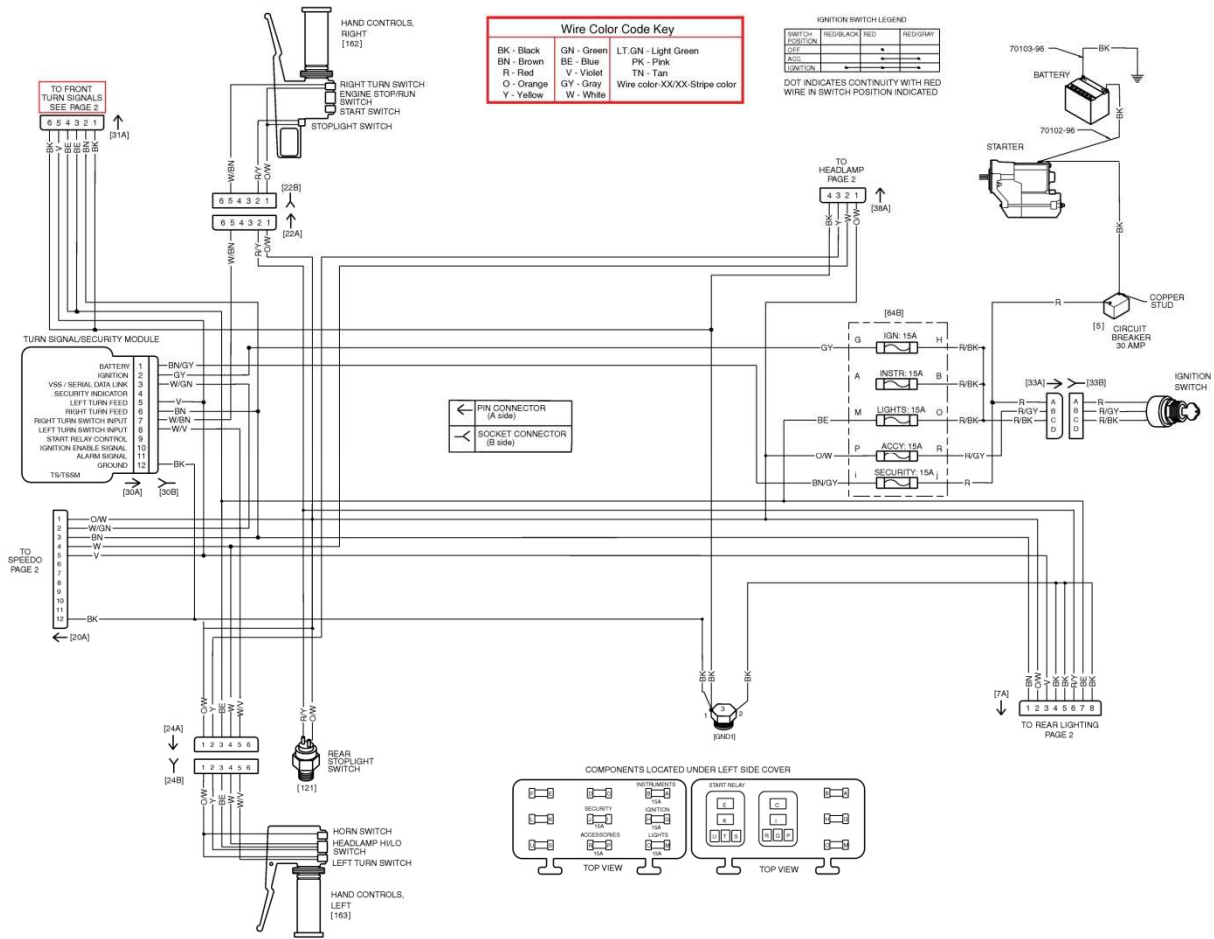

WWW.OFFICIALHARLEYPARTS.COM

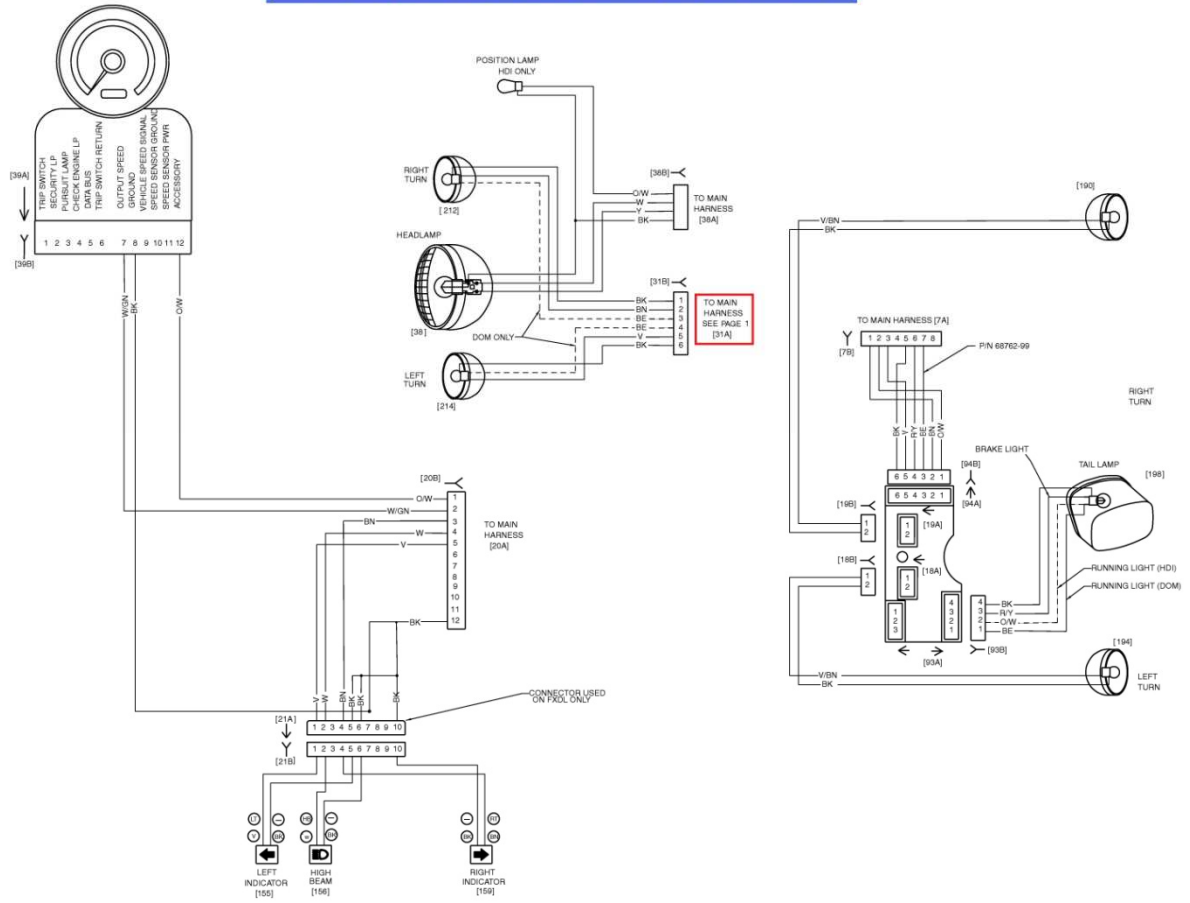

WWW.OFFICIALHARLEYPARTS.COM

2001 ALL DYNA DOM. AND INT. MODELS (EXCEPT FXDW6), MAIN HARNESS

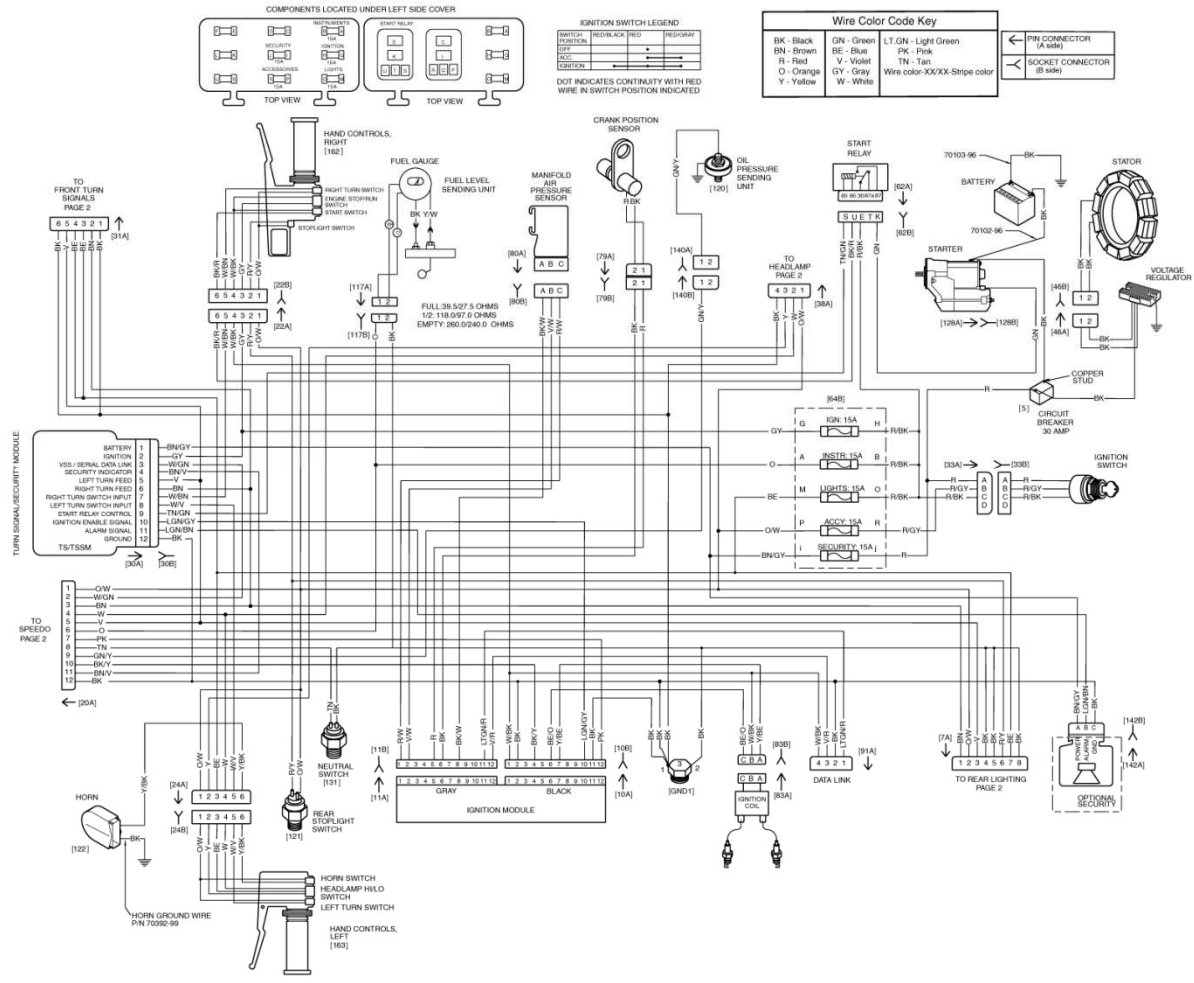

WWW.OFFICIALHARLEYPARTS.COM

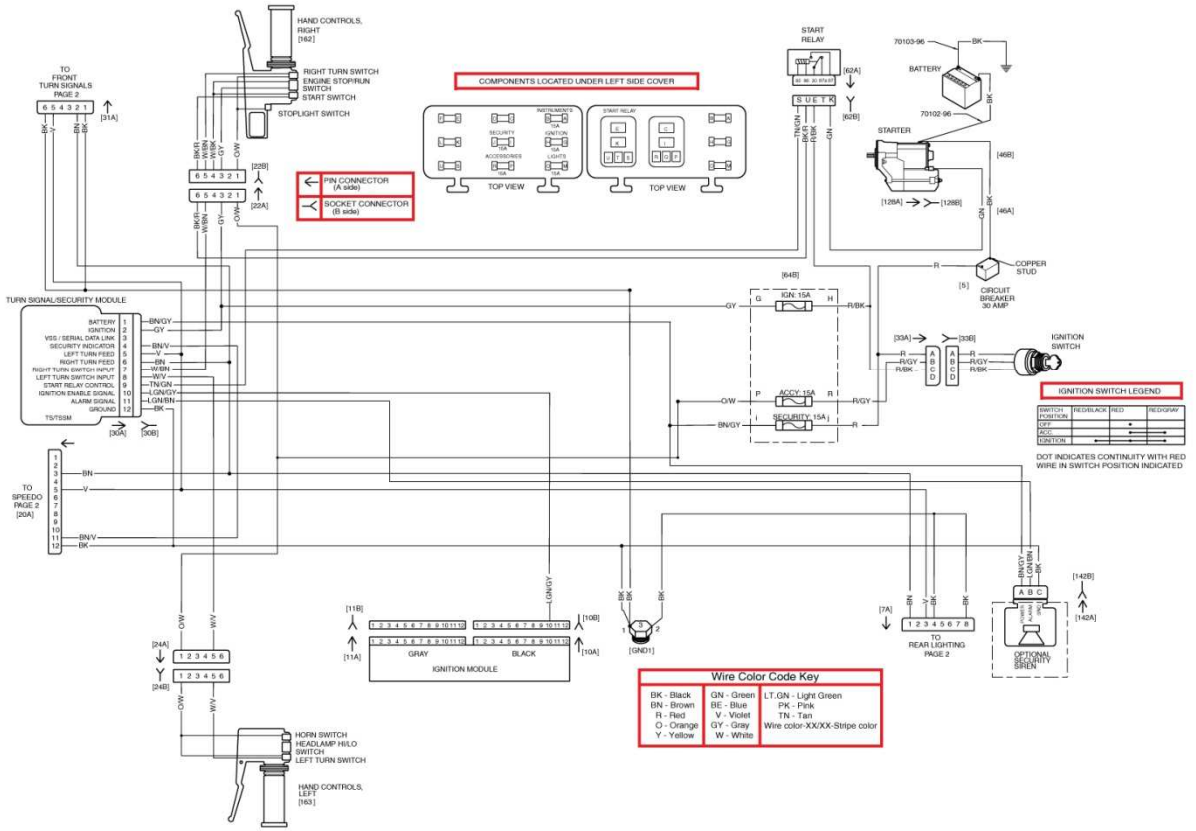

WWW.OFFICIALHARLEYPARTS.COM

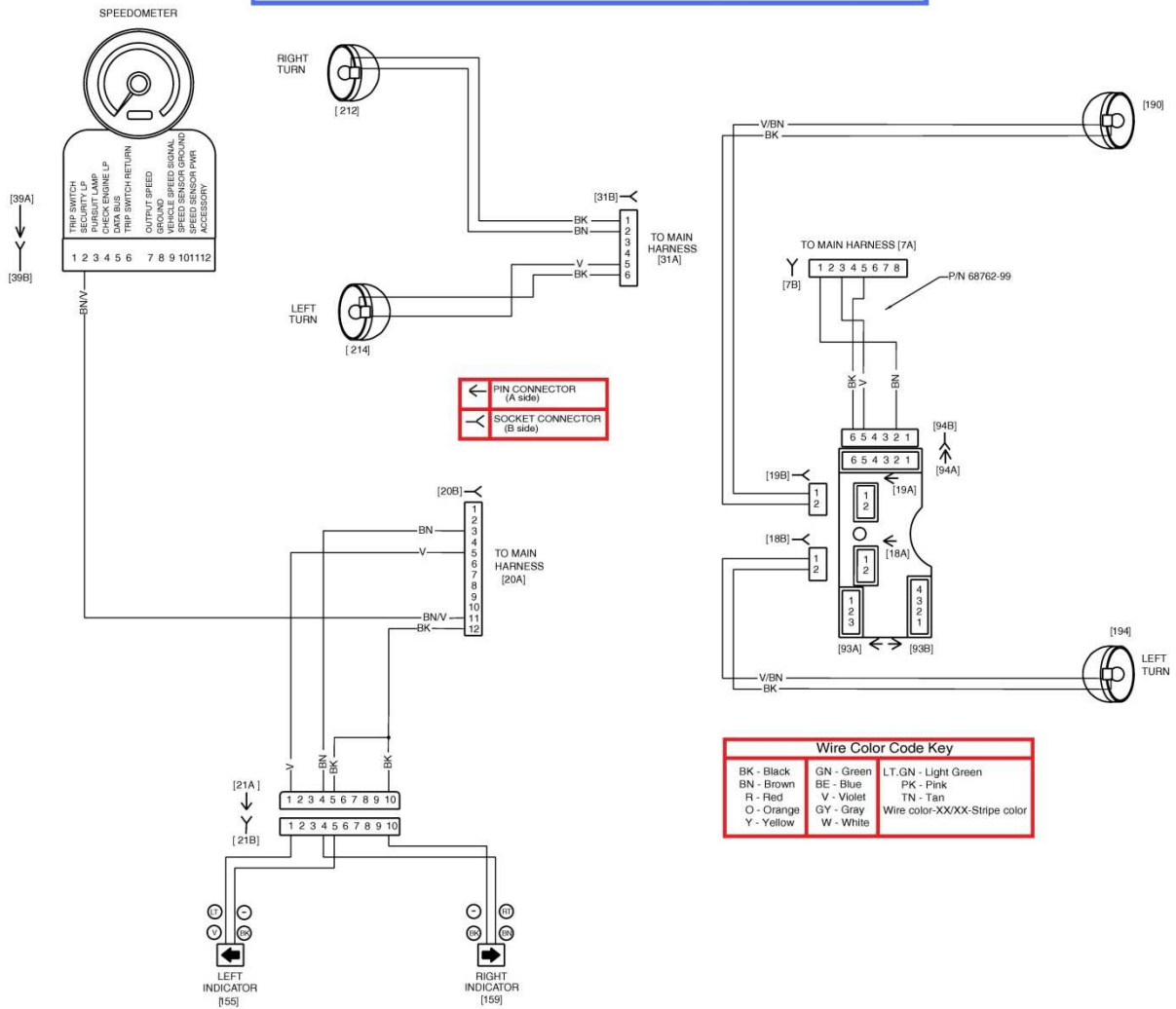

WWW.OFFICIALHARLEYPARTS.COM

2001 ALL DYNA DOM. AND INT. MODELS (EXCEPT FXDWG), STARTING CIRCUIT

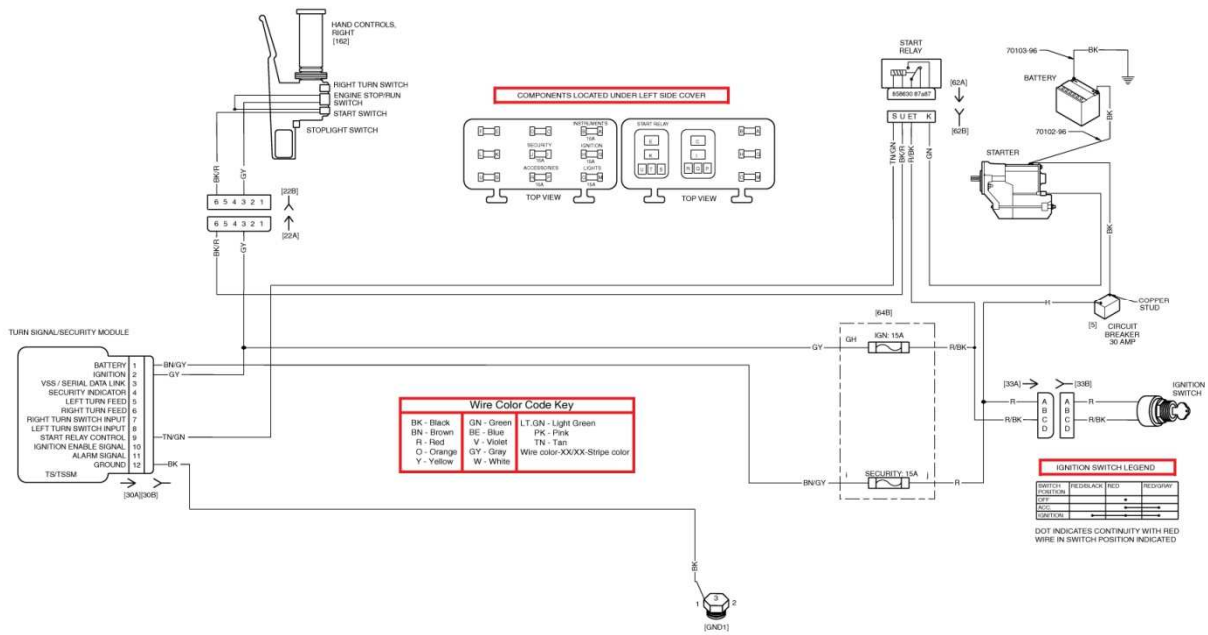

2001 ALL FXDWG DOM. AND INT. MODELS, CHARGING CIRCUIT

